

INSTRUCTION MANUAL

for the

GLOBE

"Voice Control"

MODEL VOX-10

Manufactured by
GLOBE ELECTRONICS, INC.
Council Bluffs, Iowa

MANUFACTURERS OF

World Famous Globe Transmitters

CONNECTING THE VOX-10 TO THE GLOBE CHAMPION 300 AND 300-A

1. Install an octal socket on the rear of the transmitter chassis to the left of the key jack. Designate the octal socket SOX.

2. View of key jack J-1.

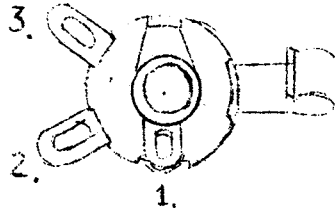

Figure 1

3. Connect a length of #20 insulated wire from pin 1 of SOX to lug 1 of J-1. See Fig. 1.

4. Connect a length of #20 insulated wire from pin 4 of SOX to lead #1 of the PC-81.

5. Connect one lead of a .01 disc to pin 5 of the 6AQ5 socket. Connect a length of hook-up wire from the other lead of the .01 disc and route to pin 5 of SOX. Keep this lead away from wires carrying AC or RF.

6. Connect a length of hook-up wire from pin 6 of SOX to pin 4 of the 6AQ5 socket.

7. Connect a length of hook-up wire from pin 8 of SOX to lug 3 of key jack J-1. See Fig. 1.

8. Connect a .002 @ 2500 VDCW mica across the primary of the modulation transformer.

9. Slip a 5-foot piece of 2-wire lamp cord through the grommet that the main power cord passes through. Route inside transmitter to the transmit switch SW-3.

10. Disconnect the orange wire from the transmit switch SW-3. (In early 300 transmitters there may be two orange wires in which case the desired orange wire is the one at the TOP of SW-3.) Attach one lead of the lamp cord to the orange wire just removed, tape well. Connect the other lamp cord lead to the terminal of SW-3 where the orange wire was removed.

11. Connect the ends of the above lamp cord outside the transmitter to pins 7 and 9 of the 9-pin plug supplied with the VOX-10 and plug into the back of the VOX-10.

12. Insert an open circuit plug into the key jack of the transmitter. Leave the Transmit switch in the ON position AFTER tune-up of the transmitter in the normal manner. Refer to the VOX-10 manual for operation.

CONNECTING THE VOX-10 TO THE GLOBE SCOUT TRANSMITTERS

1. Install an octal socket (designate SOX) on the rear of the transmitter chassis between the original accessory socket and the fuse post.
2. Connect a short length of hook-up wire from pin 1 of SOX to the nearest ground lug.
3. Attach two 25,000 ohm 10-watt resistors in series. Put this 50,000 ohm combination across the B-plus line at the junction of the power supply filter choke and filter condenser, hooking the other end of the 50K combination to ground. Run a length of hook-up wire from pin 4 of SOX to the junction of the two 25,000 ohm resistors.
4. Connect one lead of a .01 disc to pin 5 of the 6L6G modulator tube. Attach a length of hook-up wire to reach from the other lead of the .01 to pin 5 of SOX. Keep this lead dressed away from all wires carrying AC or RF.
5. Connect a length of hook-up wire from pin 6 of SOX to the HOT filament pin on the 6L6G tube socket.
6. Connect a length of hook-up wire from pin 8 of SOX to the TIP terminal of the key jack. Insert an open plug in the key jack as the VOX relay will key the transmitter.
7. Plug the VOX-10 into the newly installed socket SOX.
8. On older 65 series transmitters, there may be a connection on the PHONE-CW switch which grounds the RF tube cathode circuits. In such case, the ground should be removed from the PHONE-CW switch.

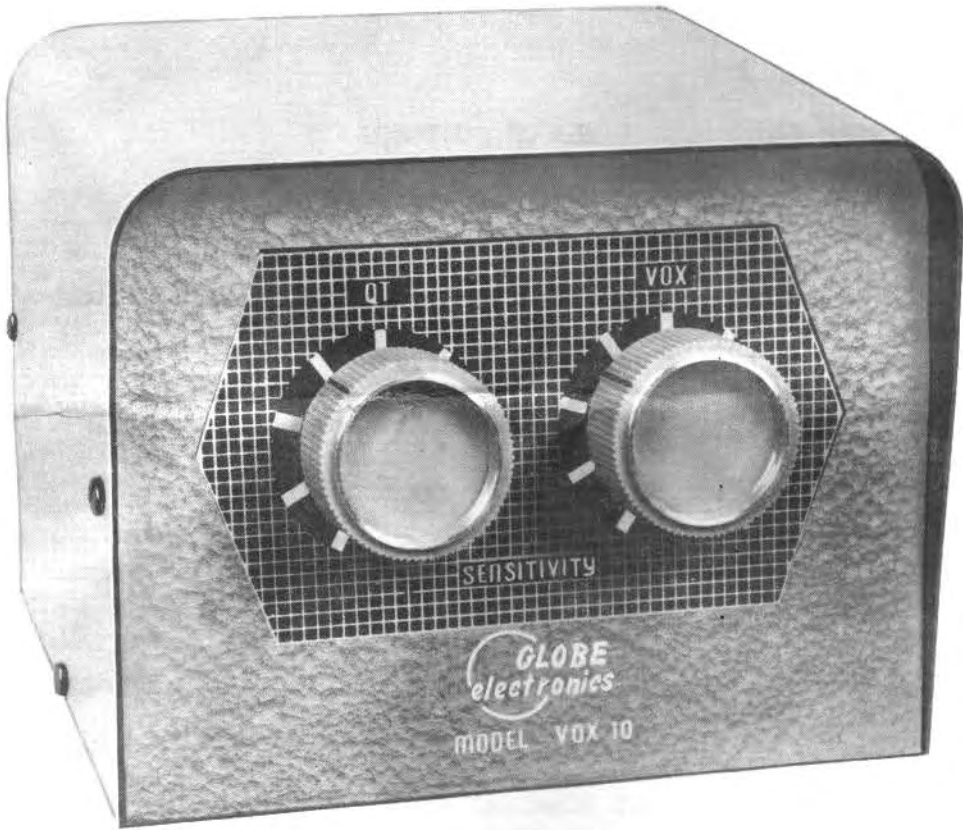

SECTION I

GENERAL DESCRIPTION

1-1. SPECIFICATIONS

- a. Power Requirements (VOX-10 and QT-10): 300v D. C. @ 20 ma
6.3v A. C. @ 0.6 amp.
- b. Relay Switching Circuits: Internal - 1; External - 3.
- c. Tubes: One 12AX7 relay control tube, VOX-10. One 12AX7 amplifier in QT-10.
- d. Size: 4-3/8" H x 5-7/8" W x 5" D.
- e. Net Weight: 2-1/4 lbs.
- f. Shipping Weight: 3-1/2 lbs.

1-2. GENERAL

The voice control unit model VOX-10 is manufactured by Globe Electronics, Inc. of Council Bluffs, Iowa. The VOX-10 was designed primarily for use with the Globe Sidebander DSB-100 but may be used with any transmitter of up to 125 Watts input power, provided the transmitter is capable of supplying the necessary voltages and connections.

The QT-10 unit may be installed into the VOX-10 for complete automatic operation. Complete details are given in Paragraph 2-5.

1-3. DESCRIPTION

The VOX-10 is contained in a metal cabinet 4-3/8" high, 5-7/8" wide, and 5" deep. An inter-connecting cable is supplied with the unit in order to obtain the necessary voltages and connections. The cover of the cabinet is easily removed for servicing and inspection. Power requirements (with QT-10 installed) are 300v D. C. @ 20 ma and 6.3v A. C. @ 0.6 amps. One 12AX7 tube is employed as a relay control tube in the VOX-10.

The VOX-10 is fundamentally an electronic switching circuit which responds to audio impulses in such a manner as to actuate a relay. The relay contacts serve to switch a combination of circuits so that several external units may be made to operate simultaneously. Such action permits completely automatic station operation, almost instantaneous in response. Use of the unit permits "on the air" conversations almost identical to ordinary telephone conversations, thus making operation more informal and enjoyable.

The VOX-10 obtains its various voltages from the transmitter through an inter-connecting cable and, since the power requirements are very low, little additional drain is placed on the transmitter. The inter-connecting cable plugs directly into the accessory socket of the DSB-100; thus no wiring changes are necessary. The VOX-10 may be used with any other trans-

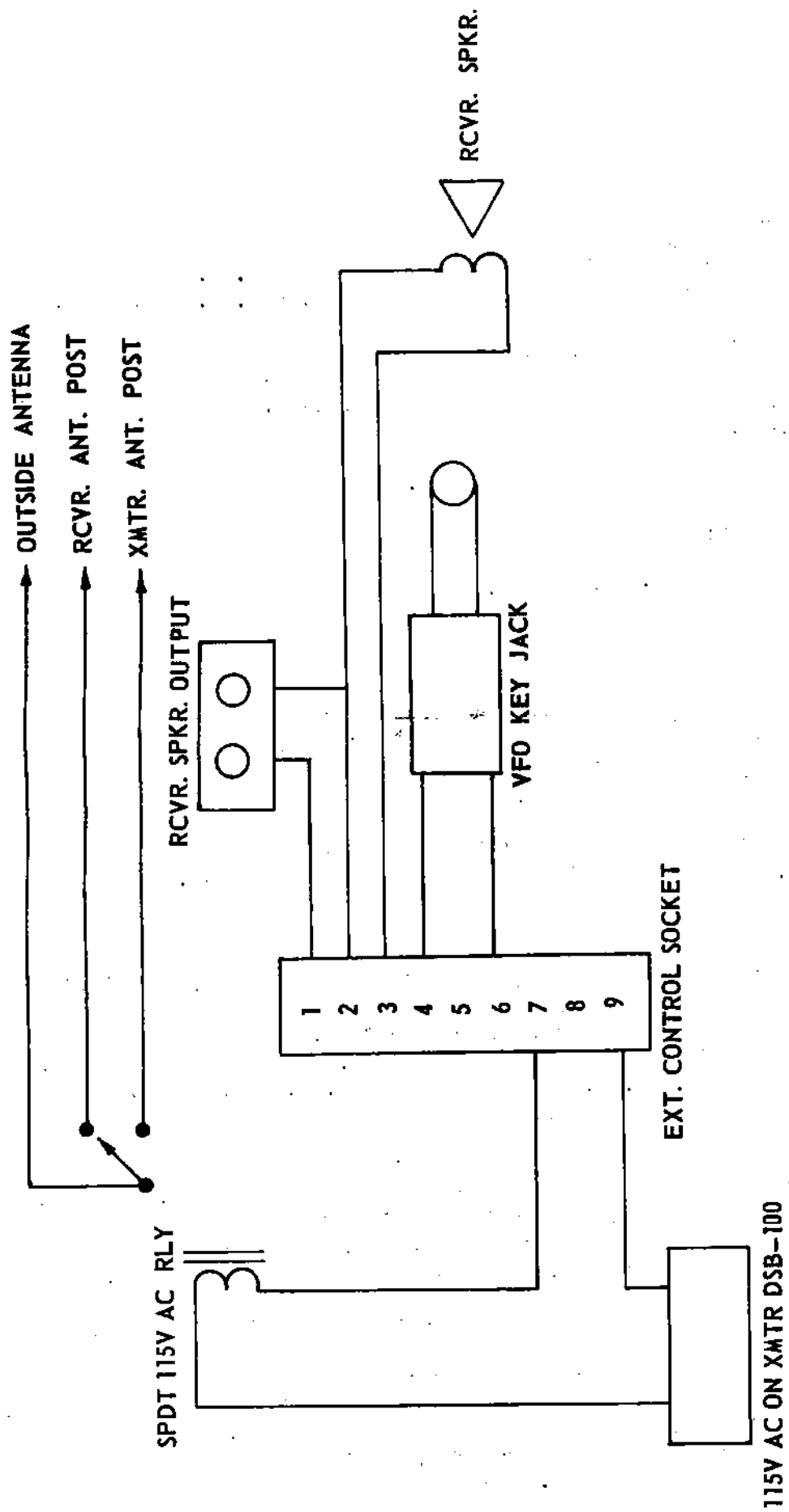

FIGURE 1 EXTERNAL CONNECTIONS

SECTION I (CONTD)

mitter of up to 125 watts input power by bringing the following voltages and connections from the transmitter through the inter-connecting cable: (a) 300v D. C. @ 20 ma (b) 6.3v A. C. @ 0.6 amps. (c) the keying line of the transmitter (d) audio voltage (a minimum of two stages of speech amplification following the microphone is necessary to insure adequate audio voltage.) (e) a grounding lead from the transmitter chassis.

SECTION II

OPERATING PROCEDURE AND INTER-CONNECTIONS

2-1. GENERAL

The following paragraphs describe the various controls of the VOX-10. Operating procedure and proper connections are outlined following the description of controls.

2-2. DESCRIPTION OF CONTROLS

- a. **VOX SENSITIVITY.** Potentiometer for controlling the sensitivity of relay control tube V1. When in MANUAL position closes VOX relay and serves as transmit/standby switch.
- b. **QT SENSITIVITY.** Potentiometer for controlling the amount of audio (from the receiver output) to the grid of the triode section of V2.
- c. **AM-CW.** Switch for completing the transmitter keying line, or cathode circuits.
- d. **TIME DELAY.** Potentiometer on rear of cabinet controls the holding time of relay RLY-1.

2-3. OPERATION WITH VOX-10 ONLY

Make all connections between the VOX-10 and the DSB-100 transmitter as shown in Fig. 1. Turn on, then begin the tune-up of the transmitter as described in its operating manual, but instead of closing the key contacts to energize the transmitter complete steps a, b, and c.

- a. Place the AM-CW switch on the rear of the VOX cabinet to AM position.
- b. Rotate the VOX SENSITIVITY control to the extreme clockwise position. This will energize its relay which in turn will energize the transmitter.
- c. Complete the transmitter tune-up procedure as instructed in its manual.
- d. When operating AM or DSB, rotate the VOX SENSITIVITY control to its mid-scale position, then modulate the transmitter

SECTION II (CONTD)

- e. If VOX operation is not desired for AM operation, leave the VOX SENSITIVITY control in the MANUAL position, then use the DSB FUNCTION switch for transmitting and standby.

2-4. The operation of Fig. 1 is as follows after DSB tune-up is completed.

When the FUNCTION switch is placed in the DSB or AM position, 115v A. C. is present at the terminal strip labelled 115v A. C. on the DSB. Speaking into the microphone or rotating the VOX SENSITIVITY control to the MANUAL position energizes the VOX relay; the relay contacts then complete the keying line of the transmitter, turns on the VFO by completing its keying line, applies 115v A. C. to the antenna relay, and switches the receiver output from the speaker to a resistive load.

When no modulation is present, the VFO, VOX, transmitter, and the antenna relay are de-energized. The antenna is switched to the receiver input and the receiver output is switched to the speaker.

When the VOX-10 is used by itself (less the QT anti-trip plug-in unit), care must be exercised to insure that the VOX and the transmitter will not be energized due to excessive speaker volume. The VOX SENSITIVITY control and the receiver volume control should be set to the point where speaker volume does not energize the VOX unit during the course of normal operation. An alternative would be to use earphones on the receiver rather than the speaker.

2-5. VOX OPERATION WITH QT-10 UNIT

The use of an anti-trip or QT circuit is recommended to eliminate the above mentioned inconvenience. The QT provides an additional refinement to the VOX unit in that balance between speaker output and microphone input is maintained, thus insuring more stable and positive operation of the VOX unit. The Globe Electronics QT-10 plugs directly into a socket provided in the VOX-10, no wiring changes need be made.

The QT-10 circuit consists of an audio speech amplifier and a diode rectifier which supplies a delay bias voltage to the VOX rectifier. In operation the unit works as follows: When receiving signals, the receiver output is coupled to the QT-10 amplifier grid through sensitivity control R-8 and transformer T-1. The audio signal is further amplified in the triode section of V2, then applied to the cathode of the diode section. Rectifier action in the diode section results in a negative D. C. voltage input which is applied to the diode plate of V1, the VOX rectifier. This voltage acts as a delay bias on the diode of V1, thus, in order to overcome it and allow operation of the VOX unit, the incoming microphone signal must be stronger. The amount of delay bias is adjusted with the QT SENSITIVITY control (R-8). The operating point which will allow normal VOX operation with adequate speaker volume will be obtained by the proper adjustment of the VOX SENSITIVITY and QT SENSITIVITY controls.

SECTION II (CONTD)

The procedure for adjustment of the VOX controls is as follows:

1. Plug the QT unit into the VOX unit.
2. Make the external connections as per Fig. 1.
3. Tune up the transmitter for DSB operation.
4. Check the VOX unit to make certain it operates. (See Paragraph 2-3)
Place the QT SENSITIVITY control to the maximum counter-clockwise position.
5. Place the transmitter GAIN control to minimum, but leave the FUNCTION switch in the DSB position.
6. Tune the receiver to a strong signal. Increase the receiver volume control until the VOX unit is actuated and goes on and off periodically.
7. Rotate the QT SENSITIVITY control in a clockwise direction until the "pumping" action of the VOX unit stops.
8. Make fine adjustments of the VOX and QT SENSITIVITY controls until the unit operates per your individual requirements.

SECTION III

MALFUNCTIONS AND PROBABLE CAUSE THEORY OF OPERATION

3-1. GENERAL

This section deals with the most likely malfunctions the operator may encounter. While the symptom may not show the exact source of the trouble, it nevertheless will serve as a helpful starting point in trouble shooting. A voltage chart is also given as an aid to determining the nature of various malfunctions.

SYMPTOM	PROBABLE CAUSE
1. Tubes will not light or unit fails to operate.	1-1. Improper power cable or plug wiring. 1-2. Improper wiring of transmitter accessory socket.
2. Relay will not energize when audio applied.	2-1. Excessive tension of relay contact arm. 2-2. Defective VOX sensitivity control R-5. 2-3. Defective time delay control R-2. 2-4. Defective tube V1.
3. Excessive VOX sensitivity required to actuate relay.	3-1. Excessive tension of relay contact arm. 3-2. Insufficient audio excitation from transmitter in use. 3-3. Weak tube V1. 3-4. QT sensitivity adjusted too high.

SECTION III (CONTD)

SYMPTOM	PROBABLE CAUSE
4. Inoperative time delay control.	4-1. Defective time delay control R-2. 4-2. Defective delay capacitor C-1. 4-3. Excessive tension of relay contact arm.
5. Lack of QT or anti-trip action.	5-1. Receiver output not matched to QT input. 5-2. Defective tube V2. 5-3. Improper QT socket wiring in VOX unit. 5-4. Improperly wired EXTERNAL CONTROL socket in VOX unit. 5-5. Relay contacts not closing properly.

3-2. TYPICAL VOLTAGE READINGS

The voltage readings given below are typical for the conditions as set forth. Some allowance must be made if the meter used is not a 20,000 ohm per volt D. C. meter.

CONDITIONS: A. C. line voltage - 115 volts; test meter - 20,000 ohms per volt D. C.; meter connected from specified pin to chassis ground; transmitter operating in DSB position, tone generator ON, VOX SENSITIVITY control in MANUAL position. All voltages D. C. unless otherwise specified.

VOLTAGE CHART

TUBE	PIN NUMBER								
	1	2	3	4	5	6	7	8	9
12AX7-V1 VOX Control	-5.2v	-5.5v	plus 30v	0	0	plus 200v	plus 15v	plus 13v	6.3 A.C.
12AX7-V2 QT Control	plus 175v	-1v	plus 1.5v	0	0	-10v	-10v	0	6.3 A.C.

SECTION III (CONTD)

3-3. THEORY OF OPERATION

The plate and grid of the first section of V1 are connected together so this section acts as a diode rectifier. Audio is impressed upon the plate of this section across grid resistor R-1. Rectification of the audio takes place in the diode and a varying positive D. C. voltage appears across the time delay control R-2. The variable D. C. voltage is then applied to the grid of the triode section of V1 through isolating resistor R-4. A negative fixed bias voltage is also applied to this grid through the bleeder network R-5 and R-6 in the cathode of this same section. With no audio present and the VOX SENSITIVITY control placed at mid-scale position, the fixed bias on the grid of the triode section cuts off all plate current, thus de-energizing relay RLY-1. When the impressed audio reaches a certain magnitude, the positive voltage applied to the grid of the triode section overcomes the fixed negative bias and allows plate current to flow, thus energizing relay RLY-1, closing all its contacts. The delay control R-2 and capacitor C-1 form a charging circuit whose discharge time is controlled by the setting of R-2. The discharge time may be adjusted so RLY-1 will "hold" or stay energized for longer or shorter periods of time depending upon the operator's choice.

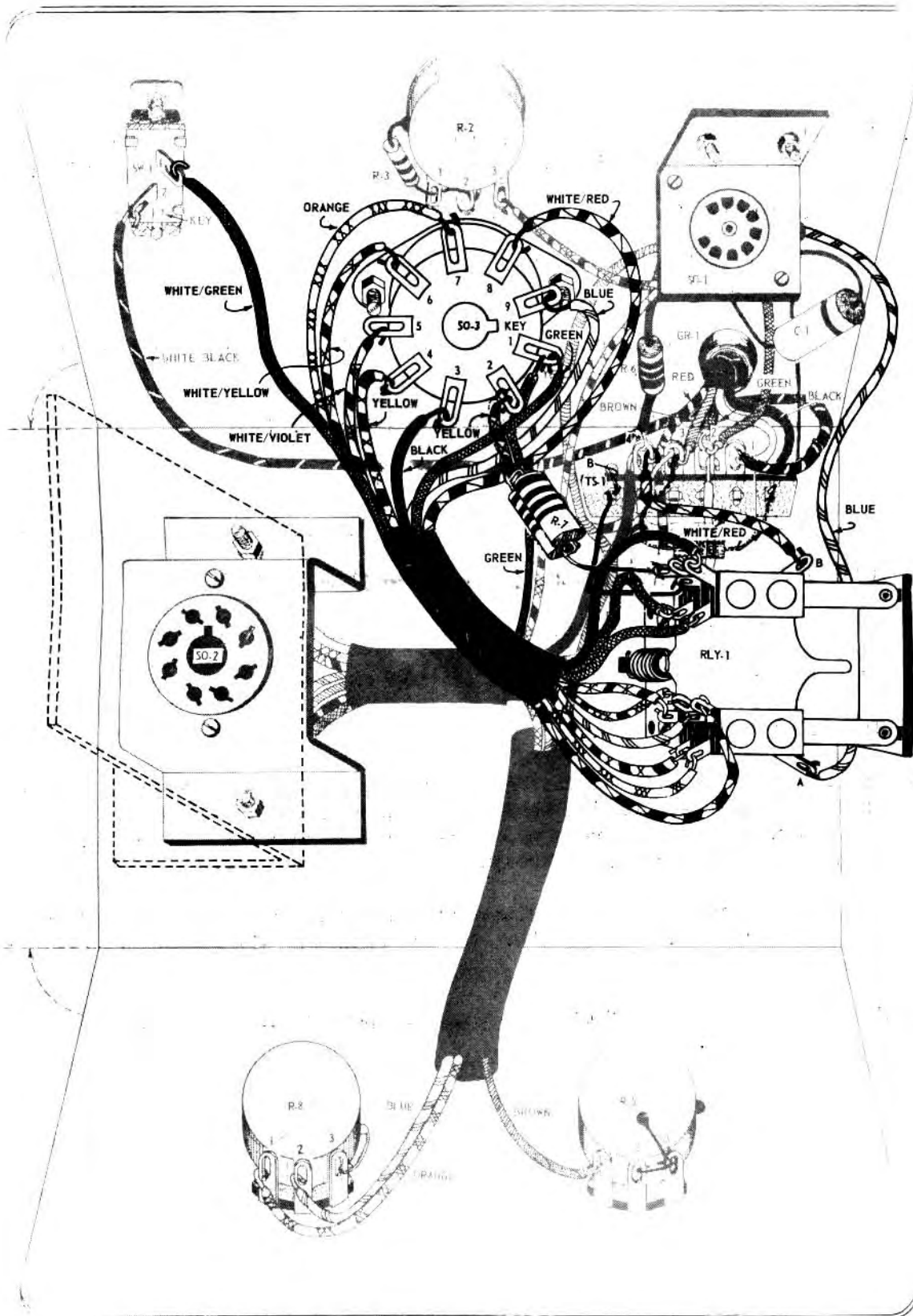

Figure 6. Relay Mounting And Wiring.

CHECKING OF RELAY CONTACTS

The relays used in the Globe Electronics VOX-10 have been thoroughly adjusted before being packed in the kit. However, during shipment or in assembly of the kit it is possible for the relay contacts to become maladjusted. Upon completion of kit wiring do not install the cabinet cover until the following checks have been completed.

- (a) Connect the VOX power plug to the DSB transmitter accessory socket.
- (b) Insert a shorting plug into the transmitter key jack. Then tune up the transmitter, following its instruction manual procedure.
- (c) Place the VOX SENSITIVITY control to full clockwise or MANUAL position. This should energize the relay and hold it closed.
- (d) Return the control to its mid-scale position, which should open the relay. Modulate the transmitter. Modulation should close the relay again for a length of time determined by the setting of TIME DELAY control on the rear of the VOX.
- (e) Remove the shorting plug from the key jack and modulate the transmitter. Speaking into the microphone should close the relay, thereby energizing the transmitter.
- (f) Trouble free operation of the relay external circuits can be assured by making the following check, using a standard ohmmeter.

1. Place the VOX SENSITIVITY control to full counter clockwise position. The relay should open.

2. Check for continuity between the following pins of the external control socket with ohmmeter test leads 1 and 3, 4 and 5, 7 and 8.

3. Should continuity not be obtained on any of these pairs of terminals, remove power from the equipment and clean and adjust contacts as follows:

Use contact cleaner or carbon tetrachloride on a toothpick or small piece of cloth and carefully clean all the contacts of the relay. Inspect the contacts and see that the normally closed contacts are making properly. If they are not, bend the upper contact blades down slightly until proper contact is made. After cleaning and adjusting, apply power to the transmitter and re-check continuity as in steps F (1-2).

4. Turn the VOX SENSITIVITY control to the full clockwise position (MANUAL). Check continuity with the ohmmeter at the external control socket as previously described. Continuity should read between the following pins:

1 and 2	4 and 6	7 and 9
---------	---------	---------

5. Remove power from the equipment if any one of the pins are not making contact properly. Gently close the relay with a finger. Note the contacts that close when the relay armature is pushed down. Clean these contacts as previously described and bend the lower contact arms up slightly so that proper continuity is made. Re-apply power to the transmitter and check continuity again as in step 4.

- (g) The cabinet cover may now be installed and rubber feet affixed.

SECTION VI

PARTS LIST VOX-10

Circuit Designation	Description	Quantity	Part Number
C-1	Capacitor, .1 mfd - 200v	1	1100-001
R-1	Resistor, 390 k ohm $\frac{1}{2}$ watt	1	1000-015
R-2	Resistor, 5 megohm potentiometer	1	2300-006
R-3	Resistor, 1 megohm $\frac{1}{2}$ watt	1	1000-023
R-4	Resistor, 1 megohm $\frac{1}{2}$ watt	1	1000-023
R-5	Resistor, 10 k ohm potentiometer	1	2300-009
R-6	Resistor, 470 k ohm $\frac{1}{2}$ watt	1	1000-021
R-7	Resistor, 10 ohm 2 watt	2	1002-004
R-8	Resistor, 500 k ohm potentiometer	1	2300-001
RLY-1	Relay	1	3500-013
SO-1	Socket, 9-pin miniature	1	1600-014
SO-2	Socket, octal	1	1600-023
SO-3	Socket, 9-pin MIP	1	1600-027
SW-1	Switch, SPST slide	1	2102-001
TS-1	Tie strip, 4-lug	1	2002-005
	Bracket, 12AX7 tube socket	1	1901-028
	Bracket, octal tube socket	1	1901-030
	Cabinet	1	1700-019
	Feet, mounting	4	3300-080
	Grommet, 3/8"	1	3200-001
	Knob	2	2600-012
	Lockwashers, #4	2	3101-001
	Lockwashers, #6	10	3101-002
	Lockwashers, #8	2	3101-003
	Lockwashers, 3/8"	3	3101-005
	Nut, 2-56 x 3/16"	2	2901-007
	Nut, 4-40 x 3/16"	2	2901-001
	Nut, 6-32 x 1/4"	10	2901-003
	Nut, 3/8"	6	2901-006
	Plug, octal	1	2001-009
	Plug, 9-pin	1	2001-014
	Plug, cap, for octal plug	1	2001-012
	Screw, 2-56 x 5/16"	2	2900-021
	Screw, 4-40 x 3/8"	2	2900-001
	Screw, 6-32 x 5/16"	10	2900-004
	Screw, 8-32 x 3/8"	1	2900-028
	Screw, self-tapping, 6 x 1/4"	6	2900-017
	Tube, 12AX7		

SECTION VI (CONTD)

Number of Pieces	Description	Length of Each Piece	Part Number
2	#20 black	5", 4"	2700-015
3	#20 blue	3-1/2", 5", 7-1/2"	2700-013
1	#20 brown	7-1/2"	2700-010
1	#20 bus wire	10"	2700-005
1	#20 gray	4"	2700-033
3	#20 green	2-3/4", 5", 3-1/2"	2700-011
2	#20 orange	3-1/2", 9-1/2"	2700-031
2	#20 yellow	2", 3-1/2"	2700-032
1	#20 white	5-1/2"	2700-016
2	#20 white/violet	3-1/4", 3-1/2"	2700-018
2	#20 white/red	2-3/4", 3-1/2"	2700-023
1	#20 white/yellow	3-1/2"	2700-020
1	#20 white/black	8"	
1	#20 white/green	6"	
1	#20 violet	5"	
1	5 conductor cable	24"	

3	Large Spaghetti	1", 1-1/2", 3"	2800-006
1	Small Spaghetti	2"	2800-008

PARTS LIST QT-10

Circuit Designation	Description	Quantity	Part Number
C-1	Capacitor, electrolytic, 25 mfd - 25v	1	1106-003
C-2	Capacitor, ceramic disc, .01 mfd - 600v	1	1101-037
C-3	Capacitor, tubular, .1 mfd - 200v	1	1100-001
R-1	Resistor, 2.2 megohm $\frac{1}{2}$ watt	1	1000-005
R-2	Resistor, 2200 ohm $\frac{1}{2}$ watt	1	1000-006
R-3	Resistor, 220,000 ohm $\frac{1}{2}$ watt	1	1000-019
R-4	Resistor, 100,000 ohm $\frac{1}{2}$ watt	1	1000-009
R-5	Resistor, 220,000 ohm $\frac{1}{2}$ watt	1	1000-019
T-1	Transformer, QT input	1	1204-006
V-1	12AX7		

QT

SCHMATIC ANTI-TRIP
PLUG-IN UNIT QT-10

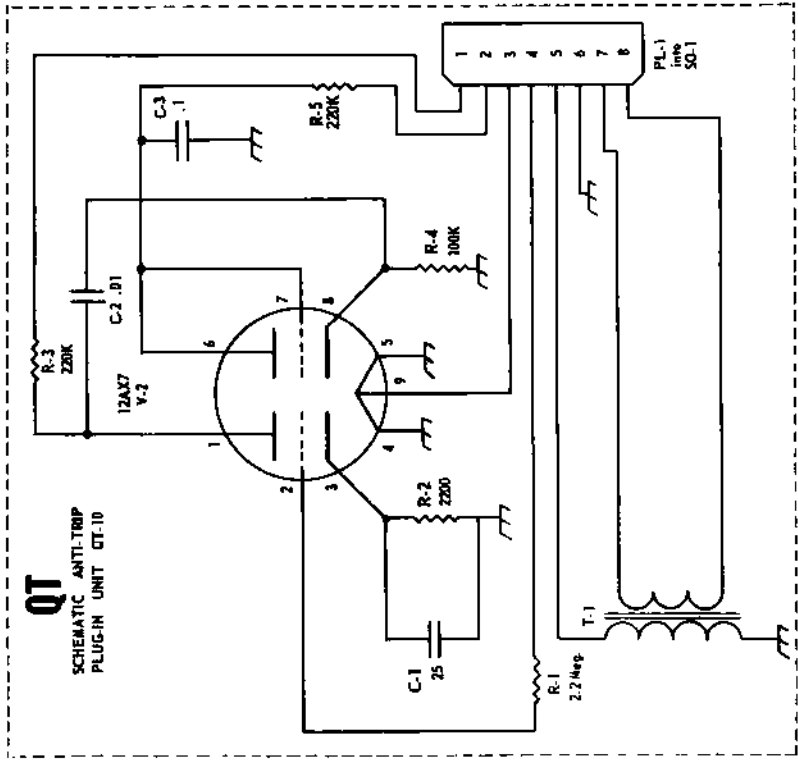

VOX

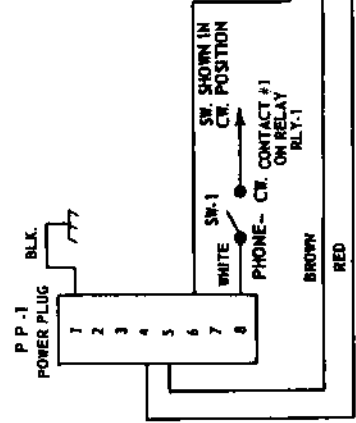
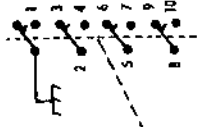
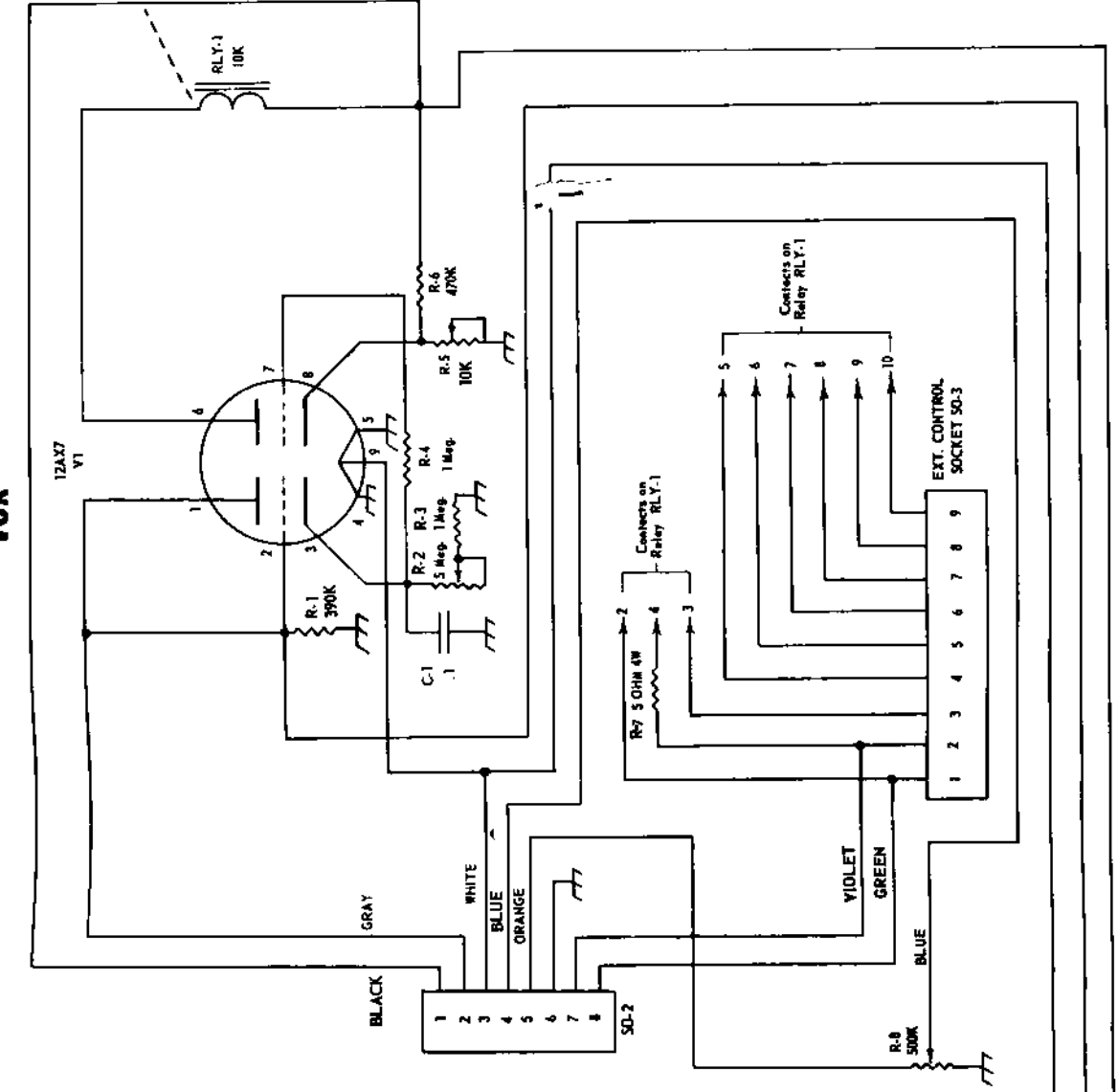

Voice Control MODEL VOX-10



WARRANTY

GLOBE Electronics, Inc. warrants each new product manufactured by it to be free from defective material and workmanship and agrees to remedy any such defect or to furnish a new part in exchange for any part of any unit of its manufacture which under normal installation, use and service discloses such defect, provided the unit is delivered by the owner to our authorized wholesaler from whom purchased, intact, for examination, with all transportation charges prepaid within ninety days from the date of sale to original purchaser and provided that such examination discloses in our judgement that it is thus defective.

This warranty does not extend to any of our products which have been subjected to misuse, neglect, accident, incorrect wiring not our own, improper installation, or to use in violation of instructions furnished by us, nor extend to units which have been repaired or altered outside of our factory, nor to cases where the serial number thereof has been removed, defaced or changed, nor to accessories used therewith not of our own manufacture. We do not authorize the purchase of any replacement for any faulty component that may be found in this unit. Under no circumstances will GLOBE Electronics, Inc. reimburse the purchaser of this unit for any such purchase.

Any part of a unit approved for remedy or exchange hereunder will be remedied or exchanged by the authorized wholesaler without charge to the owner.

This warranty applies only to the original purchaser and is not transferable. This warranty is in lieu of all other warranties expressed or implied and no representative or person is authorized to assume for us any other liability in connection with the sale of our products.

GLOBE Electronics, Inc. reserves the right to make circuit or component changes, or incorporate new features at any time without incurring any obligation to owners of its products previously sold.

K4XL's **BAMA**

This manual is provided **FREE OF CHARGE** from the "BoatAnchor Manual Archive" as a service to the Boatanchor community.

It was uploaded by someone who wanted to help you repair and maintain your equipment.

If you paid anyone other than BAMA for this manual, you paid someone who is making a profit from the free labor of others without asking their permission.

You may pass on copies of this manual to anyone who needs it. But do it without charge.

Thousands of files are available without charge from BAMA. Visit us at <http://bama.sbc.edu>